



**SECTION A. Table of Contents****Section A. Facility/Source Identification**

Table of Contents  
Site Inventory List

**Section B. General State Only Requirements**

- #001 Definitions.
- #002 Operating Permit Duration.
- #003 Permit Renewal.
- #004 Operating Permit Fees under Subchapter I.
- #005 Transfer of Operating Permits.
- #006 Inspection and Entry.
- #007 Compliance Requirements.
- #008 Need to Halt or Reduce Activity Not a Defense.
- #009 Duty to Provide Information.
- #010 Revising an Operating Permit for Cause.
- #011 Operating Permit Modifications
- #012 Severability Clause.
- #013 De Minimis Emission Increases.
- #014 Operational Flexibility.
- #015 Reactivation
- #016 Health Risk-based Emission Standards and Operating Practice Requirements.
- #017 Circumvention.
- #018 Reporting Requirements.
- #019 Sampling, Testing and Monitoring Procedures.
- #020 Recordkeeping.
- #021 Property Rights.
- #022 Alternative Operating Scenarios.
- #023 Reporting
- #024 Report Format

**Section C. Site Level State Only Requirements**

- C-I: Restrictions
- C-II: Testing Requirements
- C-III: Monitoring Requirements
- C-IV: Recordkeeping Requirements
- C-V: Reporting Requirements
- C-VI: Work Practice Standards
- C-VII: Additional Requirements
- C-VIII: Compliance Certification
- C-IX: Compliance Schedule

**Section D. Source Level State Only Requirements**

- D-I: Restrictions
- D-II: Testing Requirements
- D-III: Monitoring Requirements
- D-IV: Recordkeeping Requirements
- D-V: Reporting Requirements
- D-VI: Work Practice Standards
- D-VII: Additional Requirements

Note: These same sub-sections are repeated for each source!

**Section E. Source Group Restrictions**

- E-I: Restrictions



## SECTION A. Table of Contents

- E-II: Testing Requirements
- E-III: Monitoring Requirements
- E-IV: Recordkeeping Requirements
- E-V: Reporting Requirements
- E-VI: Work Practice Standards
- E-VII: Additional Requirements

## Section F. Alternative Operating Scenario(s)

- F-I: Restrictions
- F-II: Testing Requirements
- F-III: Monitoring Requirements
- F-IV: Recordkeeping Requirements
- F-V: Reporting Requirements
- F-VI: Work Practice Standards
- F-VII: Additional Requirements

## Section G. Emission Restriction Summary

## Section H. Miscellaneous

**SECTION A. Site Inventory List**

Source ID	Source Name	Capacity/Throughput	Fuel/Material
032	FIRE SUPPRESSION BOILER	2.700 MMBTU/HR	
101	MOLD TRADE SHOP		
102	COOLING TOWERS (3)		
103	MELT TANK(IE.MELTER/DIST/RISER/FOREHEARH		
104	QUENCH & SHOCK LEHR		
105	ANNEALING LEHRS (7), GLAZERS (1), MISC. HEAT/POL		
107	GLASS FORMING LUBRICANTS		
108	BATCH PLANT		
110	MISC.NATURAL GAS SOURCES (BOILERS/HEATERS)		
114	HI VAC CENTRAL VAC SYSTEM		
119	DECORATING LEHR (#1)		
120	PARTS WASHERS (2)		
C001	UNLOADING PIT BIN VENT		
C002	TRANSFER TOWER BIN VENT		
C003	BELT CONVEYOR BIN VENT		
C004	UNLOADING CHUTE DUST COLLECTOR		
C005	MIXED BATCH ELEVATOR DUST COLLECTOR		
C103	CADF SYSTEM		
C12	BAGHOUSE FOR #1 MOLD TRADE SHOP		
C13	BAGHOUSE FOR #2 MOLD TRADE SHOP		
C16	RAW MATERIAL ELEVATOR DUST COLLECTOR		
C17	MIXER FLOOR/SCALE AREA BAGHOUSE		
C18	TUBE/CONVEYOR LOAD PNT.BIN VENT		
C19	MIXED BATCH STORAGE BIN BAGHOUSE		
C20	BATCH WETTING SCREW BIN VENT		
C21	CULLET STORAGE BAGHOUSE		
C22	CULLET BELT CONVEYOR BIN VENT		
C23	RECEIVING HOPPER/CULLET ELEV. BAGHOUSE		
S03	MELTER TANK STACK		
S04	SILO (DC) STACK		
S05	TUBE CONVEYOR STACK		
S06	MIXED BATCH STORAGE BIN		
S07	CULLET STORAGE BIN (DC)		
S103	MELT TANK CADF STACK		
S11	MOLD TRADESHOP BAGHOUSE 1		
S110	MISC. NATURAL GAS SOURCES STACKS		
S114	HI VAC CENTRAL VAC SYSTEM STACK		
S12	MOLD TRADESHOP BAGHOUSE 2		
S13	FIRE SUPPRESSION BOILER STACK		
S19	DECORATING LEHR STACK 1		

**SECTION A. Site Inventory List**

Source ID	Source Name	Capacity/Throughput	Fuel/Material
Z01	QUENCH & SHOCK LEHRS FUGITIVES		
Z02	ANNEALING LEHRS, GLAZERS, AND MISC HEAT FUGITIVES		
Z03	COOLING TOWER 1		
Z04	COOLING TOWER 2		
Z08	FUGITIVE		
Z09	AIR COMP COOLING TOWER		
Z107	GLASS FORMING FUGITIVES		
Z120	FUGITIVE EMISSIONS (PARTS WASHERS)		

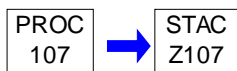
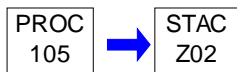
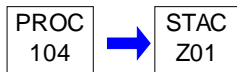
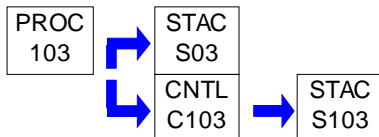
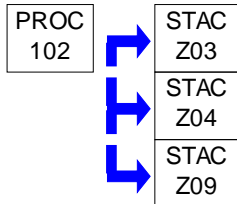
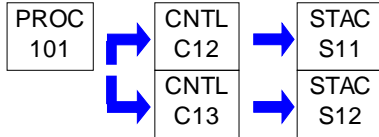
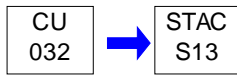
**PERMIT MAPS**

## PERMIT MAPS

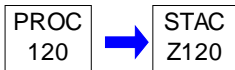
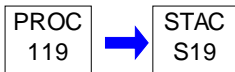
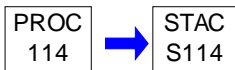
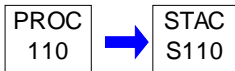
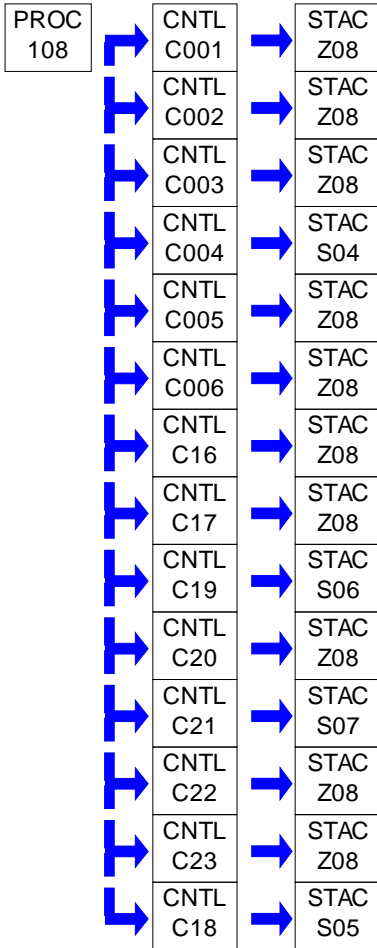

**SECTION B. General State Only Requirements****#001 [25 Pa. Code § 121.1]****Definitions.**

Words and terms that are not otherwise defined in this permit shall have the meanings set forth in Section 3 of the Air Pollution Control Act (35 P.S. § 4003) and in 25 Pa. Code § 121.1.

**#002 [25 Pa. Code § 127.446]****Operating Permit Duration.**

- (a) This operating permit is issued for a fixed term of five (5) years and shall expire on the date specified on Page 1 of this permit.
- (b) The terms and conditions of the expired permit shall automatically continue pending issuance of a new operating permit, provided the permittee has submitted a timely and complete application and paid applicable fees required under 25 Pa. Code Chapter 127, Subchapter I and the Department is unable, through no fault of the permittee, to issue or deny a new permit before the expiration of the previous permit.

**#003 [25 Pa. Code §§ 127.412, 127.413, 127.414, 127.446 & 127.703(b)]****Permit Renewal.**

- (a) The permittee shall submit a timely and complete application for renewal of the operating permit to the appropriate Regional Air Program Manager. The application for renewal of the operating permit shall be submitted at least six (6) months and not more than 18 months before the expiration date of this permit.
- (b) The application for permit renewal shall include the current permit number, a description of any permit revisions that occurred during the permit term, and any applicable requirements that were promulgated and not incorporated into the permit during the permit term. An application is complete if it contains sufficient information to begin processing the application, has the applicable sections completed and has been signed by a responsible official.
- (c) The permittee shall submit with the renewal application a fee for the processing of the application as specified in 25 Pa. Code § 127.703(b). The fees shall be made payable to "The Commonwealth of Pennsylvania Clean Air Fund" and submitted with the fee form to the respective regional office.
- (d) The renewal application shall also include submission of proof that the local municipality and county, in which the facility is located, have been notified in accordance with 25 Pa. Code § 127.413.
- (e) The application for renewal of the operating permit shall also include submission of supplemental compliance review forms in accordance with the requirements of 25 Pa. Code § 127.412(b) and § 127.412(j).
- (f) The permittee, upon becoming aware that any relevant facts were omitted or incorrect information was submitted in the permit application, shall promptly submit such supplementary facts or corrected information as necessary to address any requirements that become applicable to the source after the permittee submits a complete application, but prior to the date the Department takes action on the permit application.

**#004 [25 Pa. Code § 127.703]****Operating Permit Fees under Subchapter I.**

- (a) The permittee shall pay the annual operating permit maintenance fee according to the following fee schedule in either paragraph (1) or (2) in accordance with 25 Pa. Code § 127.703(d) on or before December 31 of each year for the next calendar year.
- (1) For a synthetic minor facility, a fee equal to:
- (i) Four thousand dollars (\$4,000) for calendar years 2021—2025.
  - (ii) Five thousand dollars (\$5,000) for calendar years 2026—2030.
  - (iii) Six thousand three hundred dollars (\$6,300) for the calendar years beginning with 2031.

**SECTION B. General State Only Requirements**

(2) For a facility that is not a synthetic minor, a fee equal to:

- (i) Two thousand dollars (\$2,000) for calendar years 2021—2025.
- (ii) Two thousand five hundred dollars (\$2,500) for calendar years 2026—2030.
- (iii) Three thousand one hundred dollars (\$3,100) for the calendar years beginning with 2031.

(b) The applicable fees shall be made payable to "The Commonwealth of Pennsylvania Clean Air Fund" with the permit number clearly indicated and submitted to the respective regional office.

**#005 [25 Pa. Code §§ 127.450 (a)(4) and 127.464]****Transfer of Operating Permits.**

(a) This operating permit may not be transferred to another person, except in cases of transfer-of-ownership that are documented and approved by the Department.

(b) In accordance with 25 Pa. Code § 127.450(a)(4), a change in ownership of the source shall be treated as an administrative amendment if the Department determines that no other change in the permit is required and a written agreement has been submitted to the Department identifying the specific date of the transfer of permit responsibility, coverage and liability between the current and the new permittee and a compliance review form has been submitted to, and the permit transfer has been approved by, the Department.

(c) This operating permit is valid only for those specific sources and the specific source locations described in this permit.

**#006 [25 Pa. Code § 127.441 and 35 P.S. § 4008]****Inspection and Entry.**

(a) Upon presentation of credentials and other documents as may be required by law, the permittee shall allow the Department or authorized representatives of the Department to perform the following:

(1) Enter at reasonable times upon the permittee's premises where a source is located or emissions related activity is conducted, or where records are kept under the conditions of this permit;

(2) Have access to and copy, at reasonable times, any records that are kept under the conditions of this permit;

(3) Inspect at reasonable times, any facilities, equipment including monitoring and air pollution control equipment, practices, or operations regulated or required under this permit;

(4) Sample or monitor, at reasonable times, any substances or parameters, for the purpose of assuring compliance with the permit or applicable requirements as authorized by the Clean Air Act, the Air Pollution Control Act, or the regulations promulgated under the Acts.

(b) Pursuant to 35 P.S. § 4008, no person shall hinder, obstruct, prevent or interfere with the Department or its personnel in the performance of any duty authorized under the Air Pollution Control Act or regulations adopted thereunder including denying the Department access to a source at this facility. Refusal of entry or access may constitute grounds for permit revocation and assessment of criminal and/or civil penalties.

(c) Nothing in this permit condition shall limit the ability of the EPA to inspect or enter the premises of the permittee in accordance with Section 114 or other applicable provisions of the Clean Air Act.

**#007 [25 Pa. Code §§ 127.441 & 127.444]****Compliance Requirements.**

(a) The permittee shall comply with the conditions of this operating permit. Noncompliance with this permit constitutes a violation of the Clean Air Act and the Air Pollution Control Act and is grounds for one or more of the following:



**SECTION B. General State Only Requirements**

- (1) Enforcement action
- (2) Permit termination, revocation and reissuance or modification
- (3) Denial of a permit renewal application

(b) A person may not cause or permit the operation of a source which is subject to 25 Pa. Code Article III unless the source(s) and air cleaning devices identified in the application for the plan approval and operating permit and the plan approval issued for the source is operated and maintained in accordance with specifications in the applications and the conditions in the plan approval and operating permit issued by the Department. A person may not cause or permit the operation of an air contamination source subject to 25 Pa. Code Chapter 127 in a manner inconsistent with good operating practices.

(c) For purposes of Sub-condition (b) of this permit condition, the specifications in applications for plan approvals and operating permits are the physical configurations and engineering design details which the Department determines are essential for the permittee's compliance with the applicable requirements in this State-Only permit. Nothing in this sub-condition shall be construed to create an independent affirmative duty upon the permittee to obtain a predetermination from the Department for physical configuration or engineering design detail changes made by the permittee.

**#008 [25 Pa. Code § 127.441]****Need to Halt or Reduce Activity Not a Defense.**

It shall not be a defense for the permittee in an enforcement action that it was necessary to halt or reduce the permitted activity in order to maintain compliance with the conditions of this permit.

**#009 [25 Pa. Code §§ 127.442(a) & 127.461]****Duty to Provide Information.**

(a) The permittee shall submit reports to the Department containing information the Department may prescribe relative to the operation and maintenance of each source at the facility.

(b) The permittee shall furnish to the Department, in writing, information that the Department may request to determine whether cause exists for modifying, revoking and reissuing, or terminating this permit, or to determine compliance with the permit. Upon request, the permittee shall also furnish to the Department copies of records that the permittee is required to maintain in accordance with this permit.

**#010 [25 Pa. Code § 127.461]****Revising an Operating Permit for Cause.**

This operating permit may be terminated, modified, suspended or revoked and reissued if one or more of the following applies:

- (1) The permittee constructs or operates the source subject to the operating permit so that it is in violation of the Air Pollution Control Act, the Clean Air Act, the regulations thereunder, a plan approval, a permit or in a manner that causes air pollution.
- (2) The permittee fails to properly or adequately maintain or repair an air pollution control device or equipment attached to or otherwise made a part of the source.
- (3) The permittee has failed to submit a report required by the operating permit or an applicable regulation.
- (4) The EPA determines that the permit is not in compliance with the Clean Air Act or the regulations thereunder.

**#011 [25 Pa. Code §§ 127.450, 127.462, 127.465 & 127.703]****Operating Permit Modifications**

(a) The permittee is authorized to make administrative amendments, minor operating permit modifications and significant operating permit modifications, under this permit, as outlined below:

**SECTION B. General State Only Requirements**

(b) Administrative Amendments. The permittee shall submit the application for administrative operating permit amendments (as defined in 25 Pa. Code § 127.450(a)), according to procedures specified in § 127.450 unless precluded by the Clean Air Act or its regulations.

(c) Minor Operating Permit Modifications. The permittee shall submit the application for minor operating permit modifications (as defined 25 Pa. Code § 121.1) in accordance with 25 Pa. Code § 127.462.

(d) Significant Operating Permit Modifications. The permittee shall submit the application for significant operating permit modifications in accordance with 25 Pa. Code § 127.465.

(e) The applicable fees shall be made payable to "The Commonwealth of Pennsylvania Clean Air Fund" with the permit number clearly indicated and submitted to the respective regional office.

**#012 [25 Pa. Code § 127.441]****Severability Clause.**

The provisions of this permit are severable, and if any provision of this permit is determined by a court of competent jurisdiction to be invalid or unenforceable, such a determination will not affect the remaining provisions of this permit.

**#013 [25 Pa. Code § 127.449]****De Minimis Emission Increases.**

(a) This permit authorizes de minimis emission increases in accordance with 25 Pa. Code § 127.449 so long as the permittee provides the Department with seven (7) days prior written notice before commencing any de minimis emissions increase. The written notice shall:

(1) Identify and describe the pollutants that will be emitted as a result of the de minimis emissions increase.

(2) Provide emission rates expressed in tons per year and in terms necessary to establish compliance consistent with any applicable requirement.

(b) The Department may disapprove or condition de minimis emission increases at any time.

(c) Except as provided below in (d), the permittee is authorized to make de minimis emission increases (expressed in tons per year) up to the following amounts without the need for a plan approval or prior issuance of a permit modification:

(1) Four tons of carbon monoxide from a single source during the term of the permit and 20 tons of carbon monoxide at the facility during the term of the permit.

(2) One ton of NO<sub>x</sub> from a single source during the term of the permit and 5 tons of NO<sub>x</sub> at the facility during the term of the permit.

(3) One and six-tenths tons of the oxides of sulfur from a single source during the term of the permit and 8.0 tons of oxides of sulfur at the facility during the term of the permit.

(4) Six-tenths of a ton of PM<sub>10</sub> from a single source during the term of the permit and 3.0 tons of PM<sub>10</sub> at the facility during the term of the permit. This shall include emissions of a pollutant regulated under Section 112 of the Clean Air Act unless precluded by the Clean Air Act, the regulations thereunder or 25 Pa. Code Article III.

(5) One ton of VOCs from a single source during the term of the permit and 5.0 tons of VOCs at the facility during the term of the permit. This shall include emissions of a pollutant regulated under Section 112 of the Clean Air Act unless precluded by the Clean Air Act, the regulations thereunder or 25 Pa. Code Article III.

(6) Other sources and classes of sources determined to be of minor significance by the Department.

(d) In accordance with § 127.14, the permittee is authorized to install the following minor sources without the need for a plan approval or permit modification:

**SECTION B. General State Only Requirements**

- (1) Air conditioning or ventilation systems not designed to remove pollutants generated or released from other sources.
  - (2) Combustion units rated at 2,500,000 or less Btu per hour of heat input.
  - (3) Combustion units with a rated capacity of less than 10,000,000 Btu per hour heat input fueled by natural gas supplied by a public utility or by commercial fuel oils which are No. 2 or lighter, viscosity less than or equal to 5.82 c St, and which meet the sulfur content requirements of 25 Pa. Code §123.22 (relating to combustion units). For purposes of this permit, commercial fuel oil shall be virgin oil which has no reprocessed, recycled or waste material added.
  - (4) Space heaters which heat by direct heat transfer.
  - (5) Laboratory equipment used exclusively for chemical or physical analysis.
  - (6) Other sources and classes of sources determined to be of minor significance by the Department.
- (e) This permit does not authorize de minimis emission increases if the emissions increase would cause one or more of the following:
- (1) Increase the emissions of a pollutant regulated under Section 112 of the Clean Air Act except as authorized in Subparagraphs (c)(4) and (5) of this permit condition.
  - (2) Subject the facility to the prevention of significant deterioration requirements in 25 Pa. Code Chapter 127, Subchapter D and/or the new source review requirements in Subchapter E.
  - (3) Violate any applicable requirement of this permit, the Air Pollution Control Act, the Clean Air Act, or the regulations promulgated under either of the acts.
- (f) Emissions authorized under this permit condition shall be included in the monitoring, recordkeeping and reporting requirements of this permit.
- (g) Except for de minimis emission increases, installation of minor sources made pursuant to this permit condition and Plan Approval Exemptions under 25 Pa. Code § 127.14 (relating to exemptions), the permittee is prohibited from making changes or engaging in activities that are not specifically authorized under this permit without first applying for a plan approval. In accordance with § 127.14(b), a plan approval is not required for the construction, modification, reactivation, or installation of the sources creating the de minimis emissions increase.
- (h) The permittee may not meet de minimis emission threshold levels by offsetting emission increases or decreases at the same source.

**#014 [25 Pa. Code § 127.3]****Operational Flexibility.**

The permittee is authorized to make changes within the facility in accordance with the regulatory provisions outlined in 25 Pa. Code § 127.3 (relating to operational flexibility) to implement the operational flexibility requirements provisions authorized under Section 6.1(i) of the Air Pollution Control Act and the operational flexibility terms and conditions of this permit. The provisions in 25 Pa. Code Chapter 127 which implement the operational flexibility requirements include the following:

- (1) Section 127.14 (relating to exemptions)
- (2) Section 127.447 (relating to alternative operating scenarios)
- (3) Section 127.448 (relating to emissions trading at facilities with Federally enforceable emissions caps)
- (4) Section 127.449 (relating to de minimis emission increases)
- (5) Section 127.450 (relating to administrative operating permit amendments)

**SECTION B. General State Only Requirements**

(6) Section 127.462 (relating to minor operating permit modifications)

(7) Subchapter H (relating to general plan approvals and general operating permits)

**#015 [25 Pa. Code § 127.11]****Reactivation**

(a) The permittee may not reactivate a source that has been out of operation or production for at least one year unless the reactivation is conducted in accordance with a plan approval granted by the Department or in accordance with reactivation and maintenance plans developed and approved by the Department in accordance with 25 Pa. Code § 127.11a(a).

(b) A source which has been out of operation or production for more than five (5) years but less than 10 years may be reactivated and will not be considered a new source if the permittee satisfies the conditions specified in 25 Pa. Code § 127.11a(b).

**#016 [25 Pa. Code § 127.36]****Health Risk-based Emission Standards and Operating Practice Requirements.**

(a) When needed to protect public health, welfare and the environment from emissions of hazardous air pollutants from new and existing sources, the permittee shall comply with the health risk-based emission standards or operating practice requirements imposed by the Department, except as precluded by §§ 6.6(d)(2) and (3) of the Air Pollution Control Act [35 P.S. § 4006.6(d)(2) and (3)].

(b) A person challenging a performance or emission standard established by the Department has the burden to demonstrate that performance or emission standard does not meet the requirements of Section 112 of the Clean Air Act.

**#017 [25 Pa. Code § 121.9]****Circumvention.**

No person may permit the use of a device, stack height which exceeds good engineering practice stack height, dispersion technique or other technique which, without resulting in reduction of the total amount of air contaminants emitted, conceals or dilutes an emission of air contaminants which would otherwise be in violation of 25 Pa. Code Article III, except that with prior approval of the Department, the device or technique may be used for control of malodors.

**#018 [25 Pa. Code §§ 127.402(d) & 127.442]****Reporting Requirements.**

(a) The permittee shall comply with the applicable reporting requirements of the Clean Air Act, the regulations thereunder, the Air Pollution Control Act and 25 Pa. Code Article III including Chapters 127, 135 and 139.

(b) The permittee shall submit reports to the Department containing information the Department may prescribe relative to the operation and maintenance of any air contamination source.

(c) Reports, test data, monitoring data, notifications and requests for renewal of the permit shall be submitted to the:

Regional Air Program Manager  
PA Department of Environmental Protection  
(At the address given in the permit transmittal letter, or otherwise notified)

(d) Any records or information including applications, forms, or reports submitted pursuant to this permit condition shall contain a certification by a responsible official as to truth, accuracy and completeness. The certifications submitted under this permit shall require a responsible official of the facility to certify that based on information and belief formed after reasonable inquiry, the statements and information in the documents are true, accurate and complete.

(e) Any records, reports or information submitted to the Department shall be available to the public except for such

**SECTION B. General State Only Requirements**

records, reports or information which meet the confidentiality requirements of § 4013.2 of the Air Pollution Control Act and §§ 112(d) and 114(c) of the Clean Air Act. The permittee may not request a claim of confidentiality for any emissions data generated for the facility.

**#019 [25 Pa. Code §§ 127.441(c) & 135.5]****Sampling, Testing and Monitoring Procedures.**

(a) The permittee shall comply with the monitoring, recordkeeping or reporting requirements of 25 Pa. Code Chapter 139 and the other applicable requirements of 25 Pa. Code Article III and additional requirements related to monitoring, reporting and recordkeeping required by the Clean Air Act and the regulations thereunder including the Compliance Assurance Monitoring requirements of 40 CFR Part 64, where applicable.

(b) Unless alternative methodology is required by the Clean Air Act and regulations adopted thereunder, sampling, testing and monitoring required by or used by the permittee to demonstrate compliance with any applicable regulation or permit condition shall be conducted in accordance with the requirements of 25 Pa. Code Chapter 139.

**#020 [25 Pa. Code §§ 127.441(c) and 135.5]****Recordkeeping.**

(a) The permittee shall maintain and make available, upon request by the Department, the following records of monitored information:

- (1) The date, place (as defined in the permit) and time of sampling or measurements.
- (2) The dates the analyses were performed.
- (3) The company or entity that performed the analyses.
- (4) The analytical techniques or methods used.
- (5) The results of the analyses.
- (6) The operating conditions as existing at the time of sampling or measurement.

(b) The permittee shall retain records of any required monitoring data and supporting information for at least five (5) years from the date of the monitoring, sample, measurement, report or application. Supporting information includes the calibration data and maintenance records and original strip-chart recordings for continuous monitoring instrumentation, and copies of reports required by the permit.

(c) The permittee shall maintain and make available to the Department upon request, records including computerized records that may be necessary to comply with the reporting, recordkeeping and emission statement requirements in 25 Pa. Code Chapter 135 (relating to reporting of sources). In accordance with 25 Pa. Code Chapter 135, § 135.5, such records may include records of production, fuel usage, maintenance of production or pollution control equipment or other information determined by the Department to be necessary for identification and quantification of potential and actual air contaminant emissions.

**#021 [25 Pa. Code § 127.441(a)]****Property Rights.**

This permit does not convey any property rights of any sort, or any exclusive privileges.

**#022 [25 Pa. Code § 127.447]****Alternative Operating Scenarios.**

The permittee is authorized to make changes at the facility to implement alternative operating scenarios identified in this permit in accordance with 25 Pa. Code § 127.447.

**SECTION B. General State Only Requirements****#023 [25 Pa. Code §135.3]****Reporting**

(a) If the facility is a Synthetic Minor Facility, the permittee shall submit by March 1 of each year an annual emissions report for the preceding calendar year. The report shall include information for all active previously reported sources, new sources which were first operated during the preceding calendar year, and sources modified during the same period which were not previously reported. All air emissions from the facility should be estimated and reported.

(b) A source owner or operator of a Synthetic Minor Facility may request an extension of time from the Department for the filing of an annual emissions report, and the Department may grant the extension for reasonable cause.

**#024 [25 Pa. Code §135.4]****Report Format**

If applicable, the emissions reports shall contain sufficient information to enable the Department to complete its emission inventory. Emissions reports shall be made by the source owner or operator in a format specified by the Department.

**SECTION C. Site Level Requirements****I. RESTRICTIONS.****Emission Restriction(s).****# 001 [25 Pa. Code §121.7]****Prohibition of air pollution.**

No person may permit air pollution as that term is defined in the act.

**# 002 [25 Pa. Code §123.1]****Prohibition of certain fugitive emissions**

(a) No person may permit the emission into the outdoor atmosphere of fugitive air contaminant from a source other than the following:

- (1) Construction or demolition of buildings or structures.
- (2) Grading, paving and maintenance of roads and streets.
- (3) Use of roads and streets. Emissions from material in or on trucks, railroad cars and other vehicular equipment are not considered as emissions from use of roads and streets.
- (4) Clearing of land.
- (5) Stockpiling of materials.
- (6) Open burning operations.
- (7) Not applicable.
- (8) Not applicable.
- (9) Sources and classes of sources other than those identified in paragraphs (1)-(8), for which the operator has obtained a determination from the Department that fugitive emissions from the source, after appropriate control, meet the following requirements:

- (i) the emissions are of minor significance with respect to causing air pollution; and
- (ii) the emissions are not preventing or interfering with the attainment or maintenance of any ambient air quality standard.

(b) An application form for requesting a determination under either subsection (a)(9) or 129.15(c) is available from the Department. In reviewing these applications, the Department may require the applicant to supply information including, but not limited to, a description of proposed control measures, characteristics of emissions, quantity of emissions, and ambient air quality data and analysis showing the impact of the source on ambient air quality. The applicant shall be required to demonstrate that the requirements of subsections (a)(9) and (c) and 123.2 (relating to fugitive particulate matter) or of the requirements of 129.15(c) have been satisfied. Upon such demonstration, the Department will issue a determination, in writing, either as an operating permit condition, for those sources subject to permit requirements under the act, or as an order containing appropriate conditions and limitations.

(c) See Work Practice Requirements

(d) Not applicable.

**# 003 [25 Pa. Code §123.2]****Fugitive particulate matter**

A person may not permit fugitive particulate matter to be emitted into the outdoor atmosphere from a source specified in 123.1(a)(1) -- (9) (relating to prohibition of certain fugitive emissions) if such emissions are visible at the point the emissions pass outside the person's property.

**# 004 [25 Pa. Code §123.31]****Limitations**

(a) Not applicable.

(b) A person may not permit the emission into the outdoor atmosphere of any malodorous air contaminants from any source in such a manner that the malodors are detectable outside the property of the person on whose land the source is being operated.

(c) Not applicable.

**SECTION C. Site Level Requirements****# 005 [25 Pa. Code §123.41]****Limitations**

A person may not permit the emission into the outdoor atmosphere of visible air contaminants in such a manner that the opacity of the emission is either of the following:

- (1) Equal to or greater than 20% for a period or periods aggregating more than three minutes in any 1 hour.
- (2) Equal to or greater than 60% at any time.

**# 006 [25 Pa. Code §123.42]****Exceptions**

The limitations of 123.41 (relating to limitations) shall not apply to a visible emission in any of the following instances:

- (1) When the presence of uncombined water is the only reason for failure of the emission to meet the limitations.
- (2) When the emission results from the operation of equipment used solely to train and test persons in observing the opacity of visible emissions.
- (3) When the emission results from sources specified in 123.1(a)(1) -- (9) (relating to prohibition of certain fugitive emissions).
- (4) Not applicable.

**# 007 [25 Pa. Code §127.441]****Operating permit terms and conditions.**

Facility-wide NOx emissions shall not exceed 99.0 tons per year.

[Pursuant to Plan Approval PA-04-00084C]

**# 008 [25 Pa. Code §127.441]****Operating permit terms and conditions.**

As established in Operating Permit #04-000-084, Condition #15, reductions in the allowable emission rates below the levels established herein shall not be available as Emission Reduction Credits (ERCs) pursuant to 25 PA Code Section 127.206 unless the reductions are achieved through real reductions actual or allowable emissions, whichever is lower, and unless the reductions are achieved through the installation of controls beyond those required by RACT or any other subsequent regulatory requirement.

**# 009 [25 Pa. Code §127.441]****Operating permit terms and conditions.**

In accordance with RACT Operating Permit #04-000-084, Condition #5, the Owner/Operator shall maintain records in accordance with 25 PA Code 129.95. At a minimum, the following records shall be kept for a source: operating hours, daily fuel consumption, and daily mold lubricant usage. These records shall be maintained on file for not less than five years and shall be made available to the Department upon request.

**# 010 [25 Pa. Code §129.14]****Open burning operations**

- (a) Air basins. No person may permit the open burning of material in an air basin.
- (b) Outside of air basins. Not applicable.
- (c) Exceptions: The requirements of subsections (a) and (b) do not apply where the open burning operations result from:
  - (1) A fire set to prevent or abate a fire hazard, (when approved by the Department and set by or under the supervision of a public officer.





## SECTION C. Site Level Requirements

(2) A fire set for the purpose of instructing personnel in fire fighting, when approved by the Department.

(3) A fire set for the prevention and control of disease or pests, when approved by the Department.

(4) A fire set in conjunction with the production of agricultural commodities in their unmanufactured state on the premises of the farm operation.

(5) A fire set for the purpose of burning domestic refuse, when the fire is on the premises of a structure occupied solely as a dwelling by two families or less and when the refuse results from the normal occupancy of such structure.

(6) A fire set solely for recreational or ceremonial purposes.

(7) A fire set solely for cooking food.

(d) Clearing and grubbing wastes. The following is applicable to clearing and grubbing wastes:

(1) As used in this subsection the following terms shall have the following meanings:

Air curtain destructor -- A mechanical device which forcefully projects a curtain of air across a pit in which open burning is being conducted so that combustion efficiency is increased and smoke and other particulate matter are contained.

Clearing and grubbing wastes -- Trees, shrubs, and other native vegetation which are cleared from land during or prior to the process of construction. The term does not include demolition wastes and dirt laden roots.

(2) Subsection (a) notwithstanding, clearing and grubbing wastes may be burned in a basin subject to the following requirements:

(i) Air curtain destructors shall be used when burning clearing and grubbing wastes.

(ii) Each proposed use of air curtain destructors shall be reviewed and approved by the Department in writing with respect to equipment arrangement, design and existing environmental conditions prior to commencement of burning. Proposals approved under this subparagraph need not obtain plan approval or operating permits under Chapter 127 (relating to construction modification, reactivation and operation of sources).

(iii) Approval for use of an air curtain destructor at one site may be granted for a specified period not to exceed 3 months, but may be extended for additional limited periods upon further approval by the Department.

(iv) The Department reserves the right to rescind approval granted if a determination by the Department indicates that an air pollution problem exists.

(3) Subsection (b) notwithstanding clearing and grubbing wastes may be burned outside of an air basin, subject to the following limitations:

(i) Upon receipt of a complaint or determination by the Department that an air pollution problem exists, the Department may order that the open burning cease or comply with subsection (b) of this section.

(ii) Authorization for open burning under this paragraph does not apply to clearing and grubbing wastes transported from an air basin for disposal outside of an air basin.

(4) During an air pollution episode, open burning is limited by Chapter 137 (relating to air pollution episodes) and shall cease as specified in such chapter.

**SECTION C. Site Level Requirements****II. TESTING REQUIREMENTS.**

No additional testing requirements exist except as provided in other sections of this permit including Section B (State Only General Requirements).

**III. MONITORING REQUIREMENTS.****# 011 [25 Pa. Code §123.43]****Measuring techniques**

Visible emissions may be measured using either of the following:

- (1) A device approved by the Department and maintained to provide accurate opacity measurements.
- (2) Observers, trained and qualified to measure plume opacity with the naked eye or with the aid of any devices approved by the Department.

**# 012 [25 Pa. Code §127.441]****Operating permit terms and conditions.**

A facility-wide inspection shall be conducted at a minimum of once per day when the Facility is operated by the Owner/Operator. The facility-wide inspection shall be conducted for the presence of the following:

- a. Visible stack emissions;
- b. Fugitive emissions; and
- c. Potentially objectionable odors at the property line.

These observations are to ensure continued compliance with source-specific visible emission limitations, fugitive emissions prohibited under 25 Pa. Code §123.1 or §123.2, and malodors prohibited under 25 Pa. Code §123.31. Observations for visible stack emissions shall be conducted during daylight hours and all observations shall be conducted while sources are in operation. If visible stack emissions, fugitive emissions, or potentially objectionable odors are apparent, the Owner/Operator shall take corrective action.

**IV. RECORDKEEPING REQUIREMENTS.****# 013 [25 Pa. Code §127.441]****Operating permit terms and conditions.**

Records of each daily inspection for visible stack, fugitive, and potentially objectionable odors shall be maintained in a log and at a minimum include the date, time, name and title of the observer, along with any corrective action taken as a result. These records shall be kept on site or at an alternative location acceptable to the Department for a minimum of five years and shall be made available to the Department upon request.

**# 014 [25 Pa. Code §127.441]****Operating permit terms and conditions.**

All logs and required records shall be maintained on site for a minimum of five years and shall be made available to the Department upon request.

**# 015 [25 Pa. Code §127.441]****Operating permit terms and conditions.**

In order to demonstrate compliance with the permit limits, the owner/operator shall keep and maintain the following production records on a daily basis:

- i) Raw material feed rate;
- ii) Furnace temperature; and
- iii) Electric boost rate.

These records shall be maintained on-site for a minimum period of five (5) years and made available to the Department

**SECTION C. Site Level Requirements**

upon request.

**# 016 [25 Pa. Code §135.5]****Recordkeeping**

Source owners or operators shall maintain and make available upon request by the Department records including computerized records that may be necessary to comply with § § 135.3 and 135.21 (relating to reporting; and emission statements). These may include records of production, fuel usage, maintenance of production or pollution control equipment or other information determined by the Department to be necessary for identification and quantification of potential and actual air contaminant emissions. If direct recordkeeping is not possible or practical, sufficient records shall be kept to provide the needed information by indirect means.

**V. REPORTING REQUIREMENTS.****# 017 [25 Pa. Code §127.441]****Operating permit terms and conditions.**

The Owner/Operator shall submit to the Department a copy of annual GHG reports submitted to EPA in accordance with the applicability and reporting requirements of 40 CFR 98, Mandatory Greenhouse Gas reporting.

**# 018 [25 Pa. Code §127.441]****Operating permit terms and conditions.**

The Owner/Operator of each stationary source emitting criteria pollutants (including but not limited to NO<sub>x</sub>, CO, VOC, SO<sub>x</sub>, total PM-10 and PM-2.5 (including condensable particulate matter)), and HAP shall provide the Department with a statement, in a form as the Department may prescribe, for classes or categories of sources, showing the actual emissions of criteria pollutants from that source for each reporting period. A description of the method used to calculate the emissions and the time period over which the calculation is based shall be included. The statement shall also contain a certification by a company officer or the plant manager that the information contained in the statement is accurate and shall be submitted each year by March 1 for the preceding calendar year.

**# 019 [25 Pa. Code §127.441]****Operating permit terms and conditions.**

(a) The permittee shall report malfunctions, emergencies or incidents of excess emissions to the Department. A malfunction is any sudden, infrequent, and not reasonably preventable failure of air pollution control equipment, process equipment, or a process to operate in a normal or usual manner. An emergency is any situation arising from sudden and reasonably unforeseeable events beyond the control of the owner or operator of a facility which requires immediate corrective action to restore normal operation and which causes the emission source to exceed emissions, due to unavoidable increases in emissions attributable to the situation. An emergency shall not include situations caused by improperly designed equipment, lack of preventive maintenance, careless or improper operation, or operator error.

(b) When the malfunction, emergency or incident of excess emissions poses an imminent danger to the public health, safety, welfare, or environment, it shall be reported to the Department and the County Emergency Management Agency by telephone within one (1) hour after the discovery of the malfunction, emergency or incident of excess emissions. The owner or operator shall submit a written or emailed report of instances of such malfunctions, emergencies or incidents of excess emissions to the Department within three (3) business days of the telephone report.

(c) The report shall describe the following:

1. name, permit or authorization number, and location of the facility,
2. nature and cause of the malfunction, emergency or incident,
3. date and time when the malfunction, emergency or incident was first observed,
4. expected duration of excess emissions,
5. estimated rate of emissions,
6. corrective actions or preventative measures taken.

**SECTION C. Site Level Requirements**

(d) Any malfunction, emergency or incident of excess emissions that is not subject to the notice requirements of paragraph (b) of this condition shall be reported to the Department by telephone within 24 hours (or by 4:00 PM of the next business day, whichever is later) of discovery and in writing or by e-mail within five (5) business days of discovery. The report shall contain the same information required by paragraph (c), and any permit specific malfunction reporting requirements.

(e) During an emergency an owner or operator may continue to operate the source at their discretion provided they submit justification for continued operation of a source during the emergency and follow all the notification and reporting requirements in accordance with paragraphs (b)-(d), as applicable, including any permit specific malfunction reporting requirements.

(f) Reports regarding malfunctions, emergencies or incidents of excess emissions shall be submitted to the appropriate DEP Regional Office Air Program Manager.

(g) Any emissions resulted from malfunction or emergency are to be reported in the annual emissions inventory report, if the annual emissions inventory report is required by permit or authorization.

**VI. WORK PRACTICE REQUIREMENTS.****# 020 [25 Pa. Code §123.1]****Prohibition of certain fugitive emissions**

(c) A person responsible for any source specified in subsections (a)(1) -- (7) or (9) shall take all reasonable actions to prevent particulate matter from becoming airborne. These actions shall include, but not be limited to, the following:

(1) Use, where possible, of water or chemicals for control of dust in the demolition of buildings or structures, construction operations, the grading of roads, or the clearing of land.

(2) Application of asphalt, oil, water or suitable chemicals on dirt roads, material stockpiles and other surfaces which may give rise to airborne dusts.

(3) Paving and maintenance of roadways.

(4) Prompt removal of earth or other material from paved streets onto which earth or other material has been transported by trucking or earth moving equipment, erosion by water, or other means.

**VII. ADDITIONAL REQUIREMENTS.****# 021 [25 Pa. Code §127.441]****Operating permit terms and conditions.**

If, at any time, the Department has cause to believe that air contaminant emissions from the sources listed in this operating permit may be in excess of the limitations specified in, or established pursuant to this operating permit, the permittee may be required to conduct test methods and procedures deemed necessary by the Department to determine the actual emissions rate. Such testing shall be conducted in accordance with 25 Pa. Code Chapter 139, where applicable, and in accordance with any restrictions or limitations established by the Department at such time as it notifies the company that testing is required.

**# 022 [25 Pa. Code §127.441]****Operating permit terms and conditions.**

In accordance with RACT Operating Permit 04-000-084, Condition #10 the Department may revise the emission limits based on actual emission rates.

**# 023 [25 Pa. Code §127.441]****Operating permit terms and conditions.**

Where there are conflicting requirements, the most stringent requirement will apply.

**VIII. COMPLIANCE CERTIFICATION.**

No additional compliance certifications exist except as provided in other sections of this permit including Section B (relating



**SECTION C. Site Level Requirements**

to State Only General Requirements).

**IX. COMPLIANCE SCHEDULE.**

No compliance milestones exist.

**SECTION D. Source Level Requirements**

Source ID: 032

Source Name: FIRE SUPPRESSION BOILER

Source Capacity/Throughput: 2.700 MMBTU/HR

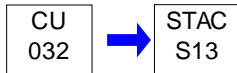
**I. RESTRICTIONS.****Emission Restriction(s).****# 001 [25 Pa. Code §123.11]****Combustion units**

(a) A person may not permit the emission into the outdoor atmosphere of particulate matter from a combustion unit in excess of the following:

(1) The rate of 0.4 pound per million Btu of heat input, when the heat input to the combustion unit in millions of Btus per hour is greater than 2.5 but less than 50.

(2)-(3) Not applicable.

(b) Not applicable.

**# 002 [25 Pa. Code §123.22]****Combustion units**

(a)-(c) Not applicable.

(d) Allegheny County, Lower Beaver Valley, and Monongahela Valley air basins. No person may permit the emission into the outdoor atmosphere of sulfur oxides, expressed as SO<sub>2</sub>, from any combustion unit in excess of any of the following:

(1) The rate of one pound per million Btu of heat input, when the heat input to the combustion unit in millions of Btus per hour is greater than 2.5 but less than 50.

(2)-(3) Not applicable.

(e) Not applicable.

**II. TESTING REQUIREMENTS.**

No additional testing requirements exist except as provided in other sections of this permit including Section B (State Only General Requirements).

**III. MONITORING REQUIREMENTS.**

No additional monitoring requirements exist except as provided in other sections of this permit including Section B (State Only General Requirements).

**IV. RECORDKEEPING REQUIREMENTS.****# 003 [25 Pa. Code §127.441]****Operating permit terms and conditions.**

All maintenance records shall be kept and maintained on-site for a period of five (5) years and made available to the Department upon request.



**SECTION D. Source Level Requirements**

**V. REPORTING REQUIREMENTS.**

No additional reporting requirements exist except as provided in other sections of this permit including Section B (State Only General Requirements).

**VI. WORK PRACTICE REQUIREMENTS.**

**# 004 [25 Pa. Code §127.441]**

**Operating permit terms and conditions.**

Compliance with mass emission limits established in this operating permit may be demonstrated using engineering calculations based on fuel and raw material purchase records, manufacturers specifications, AP-42 emission factors (or equivalent), laboratory analyses, source test results, operating records, and material balance methods.

**# 005 [25 Pa. Code §127.441]**

**Operating permit terms and conditions.**

The owner/operator shall maintain and operate the boiler in accordance with good operating practices.

**VII. ADDITIONAL REQUIREMENTS.**

No additional requirements exist except as provided in other sections of this permit including Section B (State Only General Requirements).

**SECTION D. Source Level Requirements**

Source ID: 101

Source Name: MOLD TRADE SHOP

Source Capacity/Throughput:

Conditions for this source occur in the following groups: G02-PROCESS

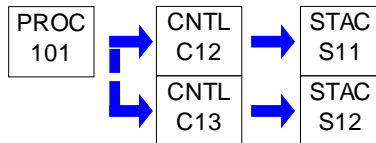
**I. RESTRICTIONS.**

No additional requirements exist except as provided in other sections of this permit including Section B (State Only General Requirements) and/or Section E (Source Group Restrictions).

**II. TESTING REQUIREMENTS.**

No additional testing requirements exist except as provided in other sections of this permit including Section B (State Only General Requirements) and/or Section E (Source Group Restrictions).

**III. MONITORING REQUIREMENTS.**

No additional monitoring requirements exist except as provided in other sections of this permit including Section B (State Only General Requirements) and/or Section E (Source Group Restrictions).

**IV. RECORDKEEPING REQUIREMENTS.**

No additional record keeping requirements exist except as provided in other sections of this permit including Section B (State Only General Requirements) and/or Section E (Source Group Restrictions).

**V. REPORTING REQUIREMENTS.**

No additional reporting requirements exist except as provided in other sections of this permit including Section B (State Only General Requirements) and/or Section E (Source Group Restrictions).

**VI. WORK PRACTICE REQUIREMENTS.**

No additional work practice requirements exist except as provided in other sections of this permit including Section B (State Only General Requirements) and/or Section E (Source Group Restrictions).

**VII. ADDITIONAL REQUIREMENTS.**

No additional requirements exist except as provided in other sections of this permit including Section B (State Only General Requirements) and/or Section E (Source Group Restrictions).



**SECTION D. Source Level Requirements**

Source ID: 102

Source Name: COOLING TOWERS (3)

Source Capacity/Throughput:

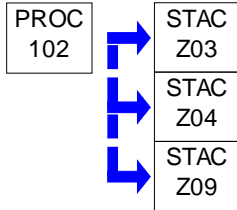
**I. RESTRICTIONS.**

No additional requirements exist except as provided in other sections of this permit including Section B (State Only General Requirements).

**II. TESTING REQUIREMENTS.**

No additional testing requirements exist except as provided in other sections of this permit including Section B (State Only General Requirements).

**III. MONITORING REQUIREMENTS.**

No additional monitoring requirements exist except as provided in other sections of this permit including Section B (State Only General Requirements).

**IV. RECORDKEEPING REQUIREMENTS.**

No additional record keeping requirements exist except as provided in other sections of this permit including Section B (State Only General Requirements).

**V. REPORTING REQUIREMENTS.**

No additional reporting requirements exist except as provided in other sections of this permit including Section B (State Only General Requirements).

**VI. WORK PRACTICE REQUIREMENTS.****# 001 [25 Pa. Code §127.441]****Operating permit terms and conditions.**

The cooling towers shall be operated in a manner that reduces drift. The reduction in drift droplets formation reduces particulate emissions from the source.

**VII. ADDITIONAL REQUIREMENTS.**

No additional requirements exist except as provided in other sections of this permit including Section B (State Only General Requirements).

**SECTION D. Source Level Requirements**

Source ID: 103

Source Name: MELT TANK(IE.MELTER/DIST/RISER/FOREHEARH

Source Capacity/Throughput:

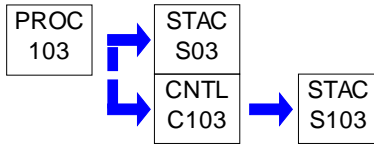
**I. RESTRICTIONS.****Emission Restriction(s).****# 001 [25 Pa. Code §123.21]****General**

(a) Not applicable.

(b) No person may permit the emission into the outdoor atmosphere of sulfur oxides from a source in a manner that the concentration of the sulfur oxides, expressed as SO<sub>2</sub>, in the effluent gas exceeds 500 parts per million, by volume, dry basis.

**# 002 [25 Pa. Code §127.441]****Operating permit terms and conditions.**

The Owner/Operator may not operate the glass melting furnace in a manner that results in emissions in excess of the following limits except during periods of start-up, shutdown, or idling as defined in 25 Pa. Code §121.1 or control system bypass (limited to 120 hours per year). Compliance with the PM<sub>10</sub> and SO<sub>2</sub> limitations shall be determined by the results of the most recent appropriate EPA reference method stack test:

- a. 1.36 pounds of NO<sub>x</sub> per ton of glass pulled on a rolling 30-day average.
- b. 0.47 pounds of total PM<sub>10</sub> (filterable and condensable) per ton of glass pulled.
- c. 0.47 pounds of SO<sub>2</sub> per ton of glass pulled.

[Pursuant to Plan Approval PA-04-00084C]

**# 003 [25 Pa. Code §127.441]****Operating permit terms and conditions.**

The emission of ammonia from the CADF system shall not exceed 10 ppmv corrected to 15% oxygen.

[Pursuant to Plan Approval PA-04-00084C]

**Throughput Restriction(s).****# 004 [25 Pa. Code §127.441]****Operating permit terms and conditions.**

Production of glass shall not exceed 300 tons of glass per day on a 30-day rolling average basis.

[Pursuant to Plan Approval PA-04-00084C]

**# 005 [25 Pa. Code §127.441]****Operating permit terms and conditions.**

The Melt Tank is considered idled when the production rate is less than 3.1 tons per hour of glass pulled.

[Pursuant to Plan Approval PA-04-00084C]

**# 006 [25 Pa. Code §127.441]****Operating permit terms and conditions.**

In accordance with RACT Operating Permit #04-000-084, Condition # 7, the owner/operator shall monitor and maintain

**SECTION D. Source Level Requirements**

excess air less than 4.5 %.

**# 007 [25 Pa. Code §127.441]****Operating permit terms and conditions.**

Pursuant to 40 CFR 63.11448(c), the glass manufacturing facility shall not use one or more continuous furnaces to produce glass that contains compounds of one or more glass metal Hazardous Air Pollutants (HAPs), which are Arsenic, Cadmium, Chromium, Lead, Manganese and Nickel, to Source 103 as raw materials in glass manufacturing batch formulation. With the exception of the owner/operator demonstrates compliance with all applicable requirements of 40 CFR Part 63 Subpart SSSSSS.

**II. TESTING REQUIREMENTS.****# 008 [25 Pa. Code §127.441]****Operating permit terms and conditions.**

Performance testing shall be conducted as follows:

- a. Stack testing for ammonia, PM, PM10, PM2.5, and SO2 by EPA Method testing shall be performed no later than December 11, 2019 and every five (5) years thereafter. Other test methods may be used if approved by the Department in writing prior to testing. Department-approved CEMS may be used in lieu of stack tests for any particular air contaminant.
- b. The Owner/Operator shall submit three copies of a pre-test protocol to the Department for review at least 60 days prior to the performance of any EPA reference method stack test (except as noted in condition i. below). All proposed performance test methods shall be identified in the pre-test protocol and approved by the Department prior to testing.
- c. The Owner/Operator shall notify the Regional Air Quality Manager at least 15 days prior to any performance test so that an observer may be present at the time of the test. Notification shall also be sent to the Division of Source Testing and Monitoring. Notification shall not be made without prior receipt of a protocol acceptance letter from the Department.
- d. All relevant operating parameters shall be recorded during the duration of the stack tests. Operating data recorded shall be sufficient to establish that the source and the air cleaning device are operating at maximum routine operating conditions. A discussion of the recorded operating parameters and values shall be included in the test report.
- e. Three (3) copies of complete test reports shall be submitted to the Department no later than 60 calendar days after completion of the on-site testing portion of an emission test program.
- f. Pursuant to 25 Pa. Code Section 139.53(b) a complete test report shall include a summary of the emission results on the first page of the report indicating if each pollutant measured is within permitted limits and a statement of compliance or non-compliance with all applicable permit conditions. The summary results will include, at a minimum, the following information:
  1. A statement that the owner or operator has reviewed the report from the emissions testing body and agrees with the findings.
  2. Permit number(s) and condition(s) which are the basis for the evaluation.
  3. Summary of results with respect to each applicable permit condition.
  4. Statement of compliance or non-compliance with each applicable permit condition.
- g. Pursuant to 25 Pa. Code § 139.3 all submittals shall meet all applicable requirements specified in the most current version of the Department's Source Testing Manual.
- h. All testing shall be performed in accordance with the provisions of Chapter 139 of the Rules and Regulations of the Department of Environmental Protection.

**SECTION D. Source Level Requirements**

i. Pursuant to 25 Pa. Code Section 139.53(a)(1) and 139.53(a)(3) all submittals, besides notifications, shall be accomplished through PSIMS\*Online available through <https://www.dep.greenport.state.pa.us/ecommm/Login.jsp> when it becomes available. If internet submittal can not be accomplished, three copies of the submittal shall be sent to the Pennsylvania Department of Environmental Protection, Bureau of Air Quality, Division of Source Testing and Monitoring, 400 Market Street, 12th Floor Rachael Carson State Office Building, Harrisburg, PA 17105-8468 with deadlines verified through document postmarks.

j. The permittee shall ensure all federal reporting requirements are followed, including timelines more stringent than those contained herein. In the event of an inconsistency or any conflicting requirements between state and the federal, the most stringent provision, term, condition, method or rule shall be used by default.

**III. MONITORING REQUIREMENTS.****# 009 [25 Pa. Code §127.441]****Operating permit terms and conditions.**

The oxygen shall be monitored twice per shift. Incoming combustion air shall be adjusted to keep the oxygen content of the exhaust gases to less than 4.5%.

**IV. RECORDKEEPING REQUIREMENTS.****# 010 [25 Pa. Code §127.441]****Operating permit terms and conditions.**

At a minimum, the Owner/Operator shall monitor and record the following CADF system parameters once per operating day:

- a. System pressure differential readings across the CADF system;
- b. Ammonia injection rate;
- c. Sorbent injection rate;
- d. Control system inlet exhaust gas temperature;
- e. Velocity of exhaust gases at the sorbent injection duct; and
- f. Broken ceramic filter detector status.

[Pursuant to Plan Approval PA-04-00084C]

**# 011 [25 Pa. Code §127.441]****Operating permit terms and conditions.**

The owner/operator shall maintain a record of all preventative maintenance inspections of the source. These inspections/maintenance records shall, at a minimum, contain the following:

- (i) Preventative maintenance schedule;
- (ii) The dates of inspections/maintenance;
- (iii) Description of any problems or defects of the control device;
- (iv) Action taken to correct problems or defects; and
- (v) Any routine maintenance performed.

The owner/operator shall develop and implement a preventative maintenance schedule within 60 days of the issuance date of the operating permit including daily, weekly, monthly, and annual inspections to ensure the source and control device is operating efficiently. These records shall be kept on-site for a minimum period of five years and shall be made available to the Department upon request.

**# 012 [25 Pa. Code §127.441]****Operating permit terms and conditions.**

The Owner/Operator shall maintain the following comprehensive and accurate records:

- a. Results of visible stack, fugitive, and malodor emission daily inspections for the sources covered by this plan approval.

**SECTION D. Source Level Requirements**

- b. The manufacturer's recommended maintenance schedule for, and all maintenance activities performed on, the CADF system.
- c. Date, duration, and glass production rate during bypass of the CADF system.
- d. Date, duration, and glass production rate when the injection of ammonia and/or sorbent ceases.
- e. 12-month rolling facility-wide NOx emissions based upon a 30-day average for the melting furnace.

[Pursuant to Plan Approval PA-04-00084C]

**# 013 [25 Pa. Code §127.441]****Operating permit terms and conditions.**

The following parameters shall be monitored and recorded once every hour during all periods of operation: glass production rate, cullet charge rate, natural gas consumption, oxygen consumption, and operating temperatures. Records of operating data shall be retained on-site for period of five (5) years and shall be made available to the Department upon request.

**# 014 [25 Pa. Code §127.441]****Operating permit terms and conditions.**

The owner/operate shall record the daily throughput of tons of glass produced per day and on a record a 30-day rolling total of glass produced per day.

**V. REPORTING REQUIREMENTS.**

No additional reporting requirements exist except as provided in other sections of this permit including Section B (State Only General Requirements).

**VI. WORK PRACTICE REQUIREMENTS.****# 015 [25 Pa. Code §127.441]****Operating permit terms and conditions.**

The Owner/Operator shall install, operate, and maintain a continuous emissions monitoring system (CEMS) for NOx in the CADF system exhaust.

[Pursuant to Plan Approval PA-04-00084C]

**# 016 [25 Pa. Code §127.441]****Operating permit terms and conditions.**

During furnace idling, the CADF system may be operated under the following alternate operating scenarios:

- a. The CADF system may be bypassed to prevent the formation of condensation in the exhaust stream if idled operation results in exhaust temperatures below 300° F at control system inlet. Control system bypass will also bypass NOx CEMS.
- b. Injection of aqueous ammonia is not required if the idled operation results in exhaust temperatures less than 450° F at control system inlet.
- c. Dry sorbent injection is not required if the idled operation results in exhaust gas velocity in the control system ductwork less than 2,000 feet per minute at sorbent injection duct.

[Pursuant to Plan Approval PA-04-00084C]

**# 017 [25 Pa. Code §127.441]****Operating permit terms and conditions.**

Other than during furnace idling, bypass of the CADF system due to maintenance, repairs, and/or malfunctions shall not exceed 120 hours per calendar year.

[Pursuant to Plan Approval PA-04-00084C]

**SECTION D. Source Level Requirements****# 018 [25 Pa. Code §127.441]****Operating permit terms and conditions.**

SO<sub>2</sub> sorbent shall be delivered to and stored at the Facility in bulk bags.

[Pursuant to Plan Approval PA-04-00084C]

**VII. ADDITIONAL REQUIREMENTS.****# 019 [25 Pa. Code §127.441]****Operating permit terms and conditions.**

For the purposes of this condition, references to any condition number below refer to source-specific requirements for Source 103, the Melt Tank, in Section D of this synthetic minor state-only operating permit.

During periods of bypass permitted in accordance with conditions #017 and #018 above, monitoring of percent excess air pursuant to Condition #009 may be used to demonstrate ongoing compliance approved in accordance with 25 Pa. Code §129.308(a).

Periods of bypass as authorized by Conditions #017 and #018 count against the minimum data availability requirements of Chapter 139, Subchapter C."

**# 020 [25 Pa. Code §129.301.]****Purpose.**

The purpose of this section and § § 129.302—129.310 is to annually limit the emissions of NO<sub>x</sub> from glass melting furnaces.

**# 021 [25 Pa. Code §129.302.]****Applicability.**

This section, § 129.301 (relating to purpose) and § § 129.303—129.310 apply to an owner or operator of a glass melting furnace in this Commonwealth, including those within the jurisdiction of local air pollution control agencies in Philadelphia and Allegheny Counties approved under section 12 of the act (35 P. S. § 4012), that emits or has the potential to emit NO<sub>x</sub> at a rate greater than 50 tons per year.

**# 022 [25 Pa. Code §129.303.]****Exemptions.**

(a) The emission requirements in § 129.304 (relating to emission requirements) do not apply during periods of start-up, shutdown, or idling as defined in § 121.1 (relating to definitions), if the owner or operator complies with the requirements in § § 129.305, 129.306 and 129.307 (relating to start-up requirements; shutdown requirements; and idling requirements).

(b) The owner or operator of a glass melting furnace claiming an exemption under subsection (a) shall notify the Department or the appropriate approved local air pollution control agency in writing within 24 hours after initiation of the operation for which the exemption is claimed. The methods for submitting the written notice may include e-mail, hand or courier delivery, certified mail or facsimile transmissions to the appropriate regional office described in § 121.4 (relating to regional organization of the Department) or appropriate approved local air pollution control agency. The notification must include:

- (1) The date and time of the start of the exempt operation.
- (2) The reason for performing the operation and an estimated completion date.
- (3) Identification of the emission control system operating during the exemption period.

(c) The owner or operator of a glass melting furnace granted an exemption under this section shall maintain operating records or documentation, or both, necessary to support the claim for the exemption. The records shall be maintained for 5 years onsite and made available or submitted to the Department or appropriate approved local air pollution control agency, upon request.

**SECTION D. Source Level Requirements**

(d) The owner or operator of a glass melting furnace shall notify the Department or the appropriate approved local air pollution control agencies in writing within 24 hours after completion of the operation for which the exemption is claimed.

**# 023 [25 Pa. Code §129.304.]****Emission requirements.**

(a) Except as specified in §§ 129.303, 129.304(c), 129.305, 129.306 and 129.307, the owner or operator of a glass melting furnace may not operate the glass melting furnace in a manner that results in NO<sub>x</sub> emissions in excess of the following allowable limits or NO<sub>x</sub> emission limits contained in the plan approval or operating permit, whichever are lower:

- (1) Not applicable.
- (2) See Miscellaneous Section of this SOOP.
- (3)-(5) Not applicable.

(b) The owner or operator of a glass melting furnace shall comply with subsection (a) by January 1, 2012, unless a petition for an alternative emission limitation or compliance schedule is submitted, in writing, to the Department and appropriate approved local air pollution control agency by January 1, 2012, in accordance with subsection (c) and approved, in writing, by the Department or appropriate approved local air pollution control agency.

(c) An owner or operator of a glass melting furnace that does not meet the NO<sub>x</sub> emission limits specified under this section by January 1, 2012, may petition the Department and appropriate approved local air pollution control agency for an alternative emission limitation or compliance schedule as follows:

- (1) The owner or operator of a glass melting furnace subject to this section may submit, in writing, a petition requesting an alternative emission limitation. The petition must demonstrate to the satisfaction of the Department and appropriate approved local air pollution control agency that it is economically or technologically infeasible to meet the emission limitation under this section. The alternative emission limitation must be included in either a plan approval or an operating permit issued by the Department or a permit issued by the appropriate approved local air pollution control agency.
- (2) The owner or operator of a glass melting furnace for which the schedule for cold shutdown does not allow compliance by January 1, 2012 may submit a petition, in writing, requesting an alternative compliance schedule. The alternative compliance schedule for a cold shutdown which occurs after June 19, 2010, may not be extended beyond 180 days from the start-up of the furnace after the cold shutdown, unless approved, in writing, by the Department.
- (3) A petition must include the following:
  - (i) A brief description, including make, model and location, of each affected glass melting furnace.
  - (ii) A list of all air pollution control technologies and measures that have been installed on each affected glass melting furnace and are operating to control emissions of NO<sub>x</sub>.
  - (iii) The date of installation and original commencement of operation for each of the technologies and measures listed in accordance with subparagraph (ii).
  - (iv) An explanation of how the NO<sub>x</sub> control technology or measure installed has been optimized for the maximum NO<sub>x</sub> emission reduction for each of the technologies and measures listed in accordance with subparagraph (ii).
  - (v) The results of each stack test and other emissions measurements for the affected glass melting furnace following the installation and commencement of operation of the air pollution control technologies and measures listed in accordance with subparagraph (ii).
  - (vi) The date of last scheduled cold shutdown for each affected furnace.
  - (vii) The date of next scheduled cold shutdown of each affected furnace.

**SECTION D. Source Level Requirements**

- (viii) Other relevant information requested, in writing, by the Department or appropriate approved local air pollution control agency.
- (4) If an alternative compliance schedule is sought to meet the requirements of this section, the owner or operator shall submit a proposed schedule containing proposed interim milestone dates for completing each phase of the required work and a proposed final compliance date. The petition must also include a proposed interim emission limitation until compliance is achieved with the requirements specified in this section.
- (5) If an alternative emission limitation is sought to meet the requirements of this section, the conditions or special circumstances which demonstrate that the applicable requirements are technologically or economically infeasible.
- (6) If an alternative emission limitation is sought to meet the requirements of this section, the owner or operator shall propose emission limitations in the petition.
- (7) Approved interim milestone dates or emission limitations determined to be necessary for effective monitoring of progress toward full compliance with the requirements of this section, §§ 129.301—129.303 and 129.305—129.310 shall be specified in a plan approval or operating permit issued by the Department or a permit issued by the appropriate approved local air pollution control agency.
- (d) During routine maintenance of an add-on emission control system or systems, or maintenance or repair measures on furnace components, the owner or operator of a glass melting furnace subject to the emission limits specified under subsection (a) is exempt from these limits if:
- (1) All routine maintenance of an add-on emission control system or maintenance or repair measures on furnace components, or both, combined, in each calendar year does not exceed 144 hours total.
  - (2) The routine maintenance or maintenance or repair measure, or both, is conducted in a manner consistent with good air pollution control practices for minimizing emissions.

**# 024 [25 Pa. Code §129.305.]****Start-up requirements.**

- (a) The owner or operator of the glass melting furnace shall submit, in writing, to the Department or appropriate approved local air pollution control agency, no later than 30 days prior to the anticipated date of start-up, information requested by the Department or appropriate approved local air pollution control agency to assure proper operation of the furnace. The information must include the following:
- (1) A detailed list of activities to be performed during start-up and an explanation for the length of time needed to complete each activity.
  - (2) A description of the material process flow rates and system operating parameters and other information that the owner or operator plans to evaluate during the process optimization.
- (b) The owner or operator of a glass melting furnace may submit a request for a start-up exemption in conjunction with the plan approval application if required. The actual length of the start-up exemption, if any, will be determined by the Department or appropriate approved local air pollution control agency at the time of the issuance of the plan approval or operating permit.
- (c) The length of the start-up exemption following activation of the primary furnace combustion system may not exceed:
- (1) Seventy days for a container, pressed or blown glass furnace.
  - (2) Not applicable.
  - (3) Not applicable.



**SECTION D. Source Level Requirements**

(d) The requirements of subsection (c) notwithstanding, if the NO<sub>x</sub> control system is not in common use or is not readily available from a commercial supplier, the length of the maximum start-up exemption following activation of the primary furnace combustion system is as follows:

- (1) One hundred days for a container, pressed or blown glass furnace.
- (2) Not applicable.
- (3) Not applicable.

(e) The Department or appropriate approved local air pollution control agency may approve start-up exemptions, as appropriate, to the extent that the submittal clearly:

- (1) Identifies the control technologies or strategies to be used.
- (2) Describes the physical conditions that prevail during start-up periods that prevent the controls from being effective.
- (3) Provides a reasonably precise estimate as to when physical conditions will have reached a state that allows for the effective control of emissions.

(f) During the start-up period, the owner or operator of a glass melting furnace shall maintain the stoichiometric ratio of the primary furnace combustion system so as not to exceed 5% excess oxygen, as calculated from the actual fuel and oxidant flow measurements for combustion in the glass melting furnace.

(g) The owner or operator shall place the emission control system in operation as soon as technologically feasible during start-up to minimize emissions.

**# 025 [25 Pa. Code §129.306.]****Shutdown requirements.**

(a) The duration of a glass melting furnace shutdown, as measured from the time the furnace operations drop below 25% of the permitted production capacity or fuel use capacity to when all emissions from the furnace cease, may not exceed 20 days.

(b) The owner or operator of a glass melting furnace shall operate the emission control system whenever technologically feasible, as approved by the Department or appropriate approved local air pollution control agency, during shutdown to minimize emissions.

**# 026 [25 Pa. Code §129.307.]****Idling requirements.**

(a) The owner or operator of a glass melting furnace shall operate the emission control system whenever technologically feasible, as approved by the Department or appropriate approved local air pollution control agency, during idling to minimize emissions.

(b) The NO<sub>x</sub> emissions during idling may not exceed the amount calculated using the following equation:

Pounds per day emission limit of NO<sub>x</sub> = (Applicable NO<sub>x</sub> emission limit specified in § 129.304(a) (relating to emission requirements) expressed in pounds per ton of glass produced) x (Furnace permitted production capacity in tons of glass produced per day)

**# 027 [25 Pa. Code §129.308.]****Compliance determination.**

(a) Not later than 14 days prior to the applicable compliance date under § 129.304(b) or (c), the owner or operator of a glass melting furnace subject to this section, §§ 129.301—129.307, 129.309 and 129.310 shall install, operate and

**SECTION D. Source Level Requirements**

maintain continuous emissions monitoring systems (CEMS, as defined in § 121.1 (relating to definitions)) for NO<sub>x</sub> and other monitoring systems to convert data to required reporting units in compliance with Chapter 139, Subchapter C (relating to requirements for source monitoring for stationary sources) and calculate actual emissions using the CEMS data reported to the Department. The owner or operator of a glass melting furnace may install or operate, or both, an alternate NO<sub>x</sub> emissions monitoring system or method, approved in writing by the Department or appropriate approved local air pollution control agency.

(b) Data invalidated under Chapter 139, Subchapter C, shall be substituted with the following if approved in writing by the Department or appropriate approved local air pollution control agency:

(1) The highest valid 1-hour emission value that occurred under similar source operating conditions during the reporting quarter.

(2) If no valid data were collected during the reporting quarter, one of the following shall be reported to the Department or appropriate approved local air pollution control agency:

(i) The highest valid 1-hour emission value that occurred under similar source operating conditions during the most recent quarter for which valid data were collected.

(ii) The highest valid 1-hour emission value that occurred under similar source operating conditions during an alternative reporting period.

(3) An alternative method of data substitution.

(c) Instead of data substitution, the Department or appropriate approved local air pollution control agency may approve an alternative procedure to quantify NO<sub>x</sub> emissions and glass production.

(d) The owner or operator of a glass furnace subject to this section shall submit to the Department or the appropriate approved local air pollution control agencies quarterly reports of CEMS monitoring data in pounds of NO<sub>x</sub> emitted per hour, in a format approved by the Department and in compliance with Chapter 139, Subchapter C, or a format approved by the appropriate approved local air pollution control agencies.

(e) The CEMS or approved monitoring system or method for NO<sub>x</sub> installed under this section must meet the minimum data availability requirements in Chapter 139, Subchapter C.

**# 028 [25 Pa. Code §129.309.]****Compliance demonstration.**

(a) The owner or operator of a glass melting furnace shall calculate and report to the Department or appropriate approved local air pollution control agency on a quarterly basis, no later than 30 days after the end of the quarter, the CEMS data and glass production data used to show compliance with the allowable NO<sub>x</sub> emission limitation specified in § 129.304 (relating to emission requirements). The glass production data must consist of the quantity of glass, in tons, pulled per day for each furnace.

(b) The owner or operator of a glass melting furnace shall demonstrate compliance with the emission requirements of § 129.304(a) using one of the following methods:

(1) On a furnace-by-furnace basis.

(2) Facility-wide emissions averaging.

(3) System-wide emissions averaging among glass melting furnaces under common control of the same owner or operator in this Commonwealth.

(c) The owner or operator of a glass melting furnace for which the Department or the appropriate approved local air pollution control agency has granted approval to voluntarily opt into a market-based program may not demonstrate

**SECTION D. Source Level Requirements**

compliance on an emissions averaging basis under subsection (b). An emission reduction obtained by emissions averaging to demonstrate compliance with the emission requirements of § 129.304(a) will not be considered surplus for emission reduction credit purposes. The owner or operator of a glass melting furnace shall demonstrate compliance with the emission requirements of § 129.304(a) in accordance with subsection (d).

(d) Compliance with the emission requirements of § 129.304(a) shall be determined on a 30-day rolling average basis.

**# 029 [25 Pa. Code §129.310.]****Recordkeeping.**

(a) The owner or operator of a glass melting furnace subject to this section and §§ 129.301—129.309 shall maintain records to demonstrate compliance. The records must include an operating log maintained for each glass melting furnace that includes, on a daily basis:

- (1) The total hours of operation.
- (2) The type and quantity of fuel used.
- (3) The quantity of glass pulled.

(b) The owner or operator of a glass melting furnace shall maintain records of:

- (1) Source tests and operating parameters established during the initial source test.
- (2) Maintenance, repairs, malfunctions, idling, start-up and shutdown.

(c) The owner or operator claiming that a glass melting furnace is exempt from the requirements of §§ 129.301—129.309 based on the furnace's potential to emit shall maintain records that clearly demonstrate to the Department or appropriate approved local air pollution control agency that the furnace is not subject to §§ 129.301—129.309.

(d) The records required under this section shall be maintained onsite for 5 years. The records shall be made available or submitted to the Department or appropriate approved local air pollution control agency upon request.

**SECTION D. Source Level Requirements**

Source ID: 104

Source Name: QUENCH &amp; SHOCK LEHR

Source Capacity/Throughput:

Conditions for this source occur in the following groups: G01-LEHRS

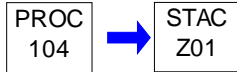
**I. RESTRICTIONS.**

No additional requirements exist except as provided in other sections of this permit including Section B (State Only General Requirements) and/or Section E (Source Group Restrictions).

**II. TESTING REQUIREMENTS.**

No additional testing requirements exist except as provided in other sections of this permit including Section B (State Only General Requirements) and/or Section E (Source Group Restrictions).

**III. MONITORING REQUIREMENTS.**

No additional monitoring requirements exist except as provided in other sections of this permit including Section B (State Only General Requirements) and/or Section E (Source Group Restrictions).

**IV. RECORDKEEPING REQUIREMENTS.**

No additional record keeping requirements exist except as provided in other sections of this permit including Section B (State Only General Requirements) and/or Section E (Source Group Restrictions).

**V. REPORTING REQUIREMENTS.**

No additional reporting requirements exist except as provided in other sections of this permit including Section B (State Only General Requirements) and/or Section E (Source Group Restrictions).

**VI. WORK PRACTICE REQUIREMENTS.**

No additional work practice requirements exist except as provided in other sections of this permit including Section B (State Only General Requirements) and/or Section E (Source Group Restrictions).

**VII. ADDITIONAL REQUIREMENTS.**

No additional requirements exist except as provided in other sections of this permit including Section B (State Only General Requirements) and/or Section E (Source Group Restrictions).

**SECTION D. Source Level Requirements**

Source ID: 105

Source Name: ANNEALING LEHRS (7), GLAZERS (1), MISC. HEAT/POL

Source Capacity/Throughput:

Conditions for this source occur in the following groups: G01-LEHRS

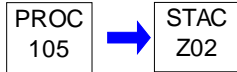
**I. RESTRICTIONS.**

No additional requirements exist except as provided in other sections of this permit including Section B (State Only General Requirements) and/or Section E (Source Group Restrictions).

**II. TESTING REQUIREMENTS.**

No additional testing requirements exist except as provided in other sections of this permit including Section B (State Only General Requirements) and/or Section E (Source Group Restrictions).

**III. MONITORING REQUIREMENTS.**

No additional monitoring requirements exist except as provided in other sections of this permit including Section B (State Only General Requirements) and/or Section E (Source Group Restrictions).

**IV. RECORDKEEPING REQUIREMENTS.**

No additional record keeping requirements exist except as provided in other sections of this permit including Section B (State Only General Requirements) and/or Section E (Source Group Restrictions).

**V. REPORTING REQUIREMENTS.**

No additional reporting requirements exist except as provided in other sections of this permit including Section B (State Only General Requirements) and/or Section E (Source Group Restrictions).

**VI. WORK PRACTICE REQUIREMENTS.**

No additional work practice requirements exist except as provided in other sections of this permit including Section B (State Only General Requirements) and/or Section E (Source Group Restrictions).

**VII. ADDITIONAL REQUIREMENTS.**

No additional requirements exist except as provided in other sections of this permit including Section B (State Only General Requirements) and/or Section E (Source Group Restrictions).

**SECTION D. Source Level Requirements**

Source ID: 107

Source Name: GLASS FORMING LUBRICANTS

Source Capacity/Throughput:

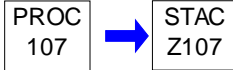
**I. RESTRICTIONS.**

No additional requirements exist except as provided in other sections of this permit including Section B (State Only General Requirements).

**II. TESTING REQUIREMENTS.**

No additional testing requirements exist except as provided in other sections of this permit including Section B (State Only General Requirements).

**III. MONITORING REQUIREMENTS.**

No additional monitoring requirements exist except as provided in other sections of this permit including Section B (State Only General Requirements).

**IV. RECORDKEEPING REQUIREMENTS.****# 001 [25 Pa. Code §127.441]****Operating permit terms and conditions.**

The Owner/Operator shall keep a monthly log of mold lubricant usage in the glass forming process. This log shall include at a minimum, type and quantity of lubricant used and emissions.

**V. REPORTING REQUIREMENTS.**

No additional reporting requirements exist except as provided in other sections of this permit including Section B (State Only General Requirements).

**VI. WORK PRACTICE REQUIREMENTS.**

No additional work practice requirements exist except as provided in other sections of this permit including Section B (State Only General Requirements).

**VII. ADDITIONAL REQUIREMENTS.**

No additional requirements exist except as provided in other sections of this permit including Section B (State Only General Requirements).

**SECTION D. Source Level Requirements**

Source ID: 108

Source Name: BATCH PLANT

Source Capacity/Throughput:

Conditions for this source occur in the following groups: G02-PROCESS

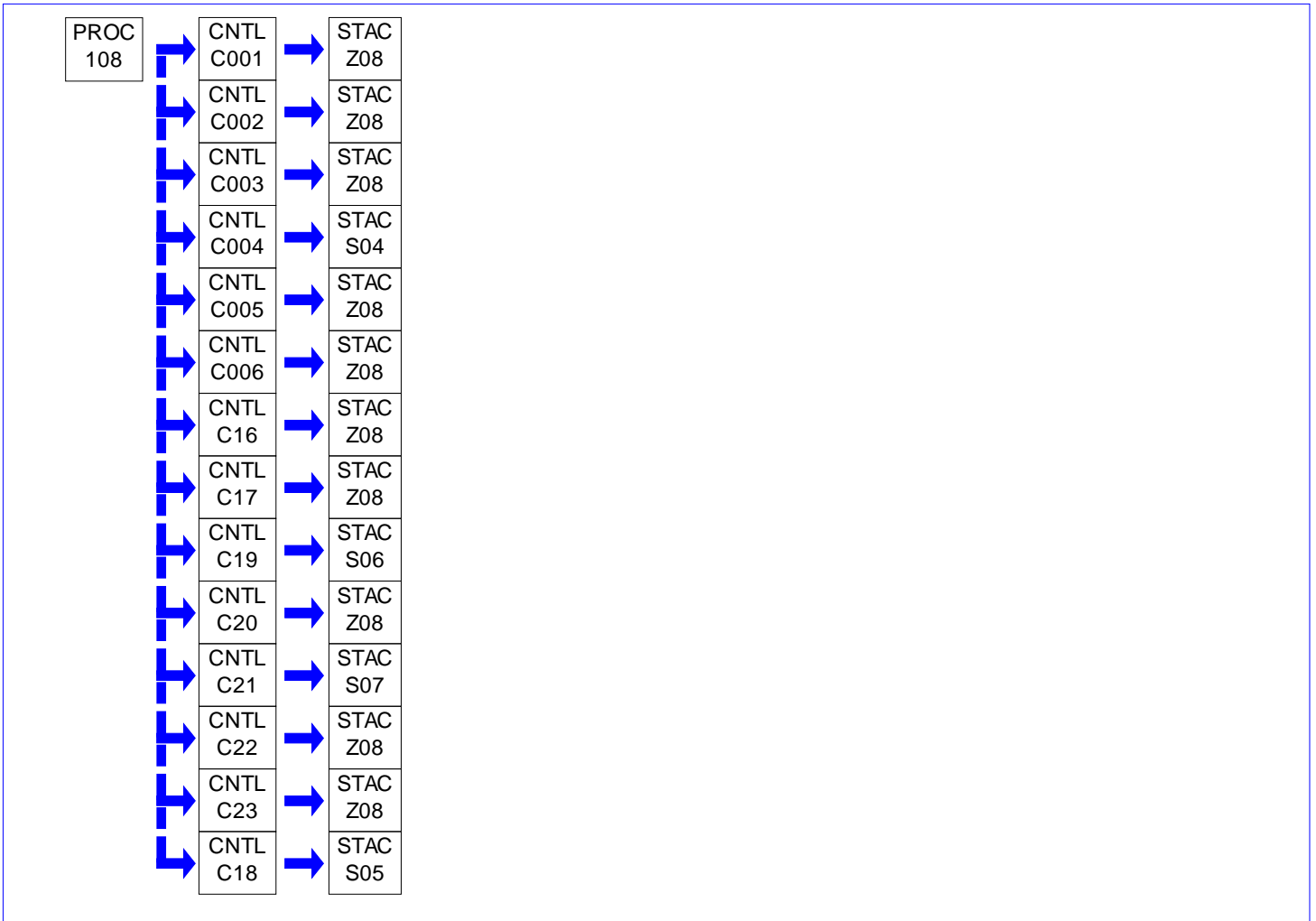
**I. RESTRICTIONS.**

No additional requirements exist except as provided in other sections of this permit including Section B (State Only General Requirements) and/or Section E (Source Group Restrictions).

**II. TESTING REQUIREMENTS.**

No additional testing requirements exist except as provided in other sections of this permit including Section B (State Only General Requirements) and/or Section E (Source Group Restrictions).

**III. MONITORING REQUIREMENTS.**

No additional monitoring requirements exist except as provided in other sections of this permit including Section B (State Only General Requirements) and/or Section E (Source Group Restrictions).



## **SECTION D. Source Level Requirements**

### **IV. RECORDKEEPING REQUIREMENTS.**

No additional record keeping requirements exist except as provided in other sections of this permit including Section B (State Only General Requirements) and/or Section E (Source Group Restrictions).

### **V. REPORTING REQUIREMENTS.**

No additional reporting requirements exist except as provided in other sections of this permit including Section B (State Only General Requirements) and/or Section E (Source Group Restrictions).

### **VI. WORK PRACTICE REQUIREMENTS.**

No additional work practice requirements exist except as provided in other sections of this permit including Section B (State Only General Requirements) and/or Section E (Source Group Restrictions).

### **VII. ADDITIONAL REQUIREMENTS.**

No additional requirements exist except as provided in other sections of this permit including Section B (State Only General Requirements) and/or Section E (Source Group Restrictions).



**SECTION D. Source Level Requirements**

Source ID: 110

Source Name: MISC.NATURAL GAS SOURCES (BOILERS/HEATERS)

Source Capacity/Throughput:

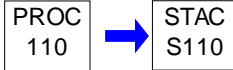
**I. RESTRICTIONS.****Emission Restriction(s).****# 001 [25 Pa. Code §123.13]****Processes**

(a)-(b) Not applicable.

(c) For processes not listed in subsection (b)(1), including but not limited to, coke oven battery waste heat stacks and autogeneous zinc coker waste heat stacks, the following shall apply:

(1) Prohibited emissions. No person may permit the emission into the outdoor atmosphere of particulate matter from any process not listed in subsection (b)(1) in a manner that the concentration of particulate matter in the effluent gas exceeds any of the following:

(i) .04 grain per dry standard cubic foot, when the effluent gas volume is less than 150,000 dry standard cubic feet per minute.

(ii)-(iii) Not applicable.

(2) Not applicable.

(d) Not applicable.

**# 002 [25 Pa. Code §123.21]****General**

(a) Not applicable.

(b) No person may permit the emission into the outdoor atmosphere of sulfur oxides from a source in a manner that the concentration of the sulfur oxides, expressed as SO<sub>2</sub>, in the effluent gas exceeds 500 parts per million, by volume, dry basis.**II. TESTING REQUIREMENTS.**

No additional testing requirements exist except as provided in other sections of this permit including Section B (State Only General Requirements).

**III. MONITORING REQUIREMENTS.**

No additional monitoring requirements exist except as provided in other sections of this permit including Section B (State Only General Requirements).

**IV. RECORDKEEPING REQUIREMENTS.****# 003 [25 Pa. Code §127.441]****Operating permit terms and conditions.**

Maintenance records shall be kept and maintained on-site for a period of five (5) years and made available to the



**SECTION D. Source Level Requirements**

Department upon request.

**V. REPORTING REQUIREMENTS.**

No additional reporting requirements exist except as provided in other sections of this permit including Section B (State Only General Requirements).

**VI. WORK PRACTICE REQUIREMENTS.**

<p><b># 004 [25 Pa. Code §127.441]</b>  <b>Operating permit terms and conditions.</b>          The owner/operator shall maintain and operate these boilers in accordance with good operating practices.</p>
<p><b># 005 [25 Pa. Code §127.441]</b>  <b>Operating permit terms and conditions.</b>          Compliance with mass emission limits established in this operating permit may be demonstrated using engineering calculations based on fuel and raw material purchase records, manufacturers specifications, AP-42 emission factors (or equivalent), laboratory analyses, source test results, operating records, and material balance methods.</p>

**VII. ADDITIONAL REQUIREMENTS.**

No additional requirements exist except as provided in other sections of this permit including Section B (State Only General Requirements).



**SECTION D. Source Level Requirements**

Source ID: 114

Source Name: HI VAC CENTRAL VAC SYSTEM

Source Capacity/Throughput:

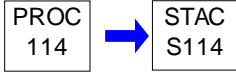

**I. RESTRICTIONS.**

No additional requirements exist except as provided in other sections of this permit including Section B (State Only General Requirements).

**II. TESTING REQUIREMENTS.**

No additional testing requirements exist except as provided in other sections of this permit including Section B (State Only General Requirements).

**III. MONITORING REQUIREMENTS.**

No additional monitoring requirements exist except as provided in other sections of this permit including Section B (State Only General Requirements).

**IV. RECORDKEEPING REQUIREMENTS.**

No additional record keeping requirements exist except as provided in other sections of this permit including Section B (State Only General Requirements).

**V. REPORTING REQUIREMENTS.**

No additional reporting requirements exist except as provided in other sections of this permit including Section B (State Only General Requirements).

**VI. WORK PRACTICE REQUIREMENTS.**

**# 001 [25 Pa. Code §127.441]**

**Operating permit terms and conditions.**

All maintenance records shall be kept and maintained on-site for a period of five (5) years and made available to the Department upon request.

**# 002 [25 Pa. Code §127.441]**

**Operating permit terms and conditions.**

The owner/operator shall maintain and operate the source in accordance with good operating practices.

**VII. ADDITIONAL REQUIREMENTS.**

No additional requirements exist except as provided in other sections of this permit including Section B (State Only General Requirements).

**SECTION D. Source Level Requirements**

Source ID: 119 Source Name: DECORATING LEHR (#1)

Source Capacity/Throughput:

Conditions for this source occur in the following groups: G01-LEHRS

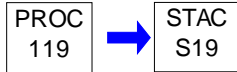
**I. RESTRICTIONS.**

No additional requirements exist except as provided in other sections of this permit including Section B (State Only General Requirements) and/or Section E (Source Group Restrictions).

**II. TESTING REQUIREMENTS.**

No additional testing requirements exist except as provided in other sections of this permit including Section B (State Only General Requirements) and/or Section E (Source Group Restrictions).

**III. MONITORING REQUIREMENTS.**

No additional monitoring requirements exist except as provided in other sections of this permit including Section B (State Only General Requirements) and/or Section E (Source Group Restrictions).

**IV. RECORDKEEPING REQUIREMENTS.**

No additional record keeping requirements exist except as provided in other sections of this permit including Section B (State Only General Requirements) and/or Section E (Source Group Restrictions).

**V. REPORTING REQUIREMENTS.**

No additional reporting requirements exist except as provided in other sections of this permit including Section B (State Only General Requirements) and/or Section E (Source Group Restrictions).

**VI. WORK PRACTICE REQUIREMENTS.**

No additional work practice requirements exist except as provided in other sections of this permit including Section B (State Only General Requirements) and/or Section E (Source Group Restrictions).

**VII. ADDITIONAL REQUIREMENTS.**

No additional requirements exist except as provided in other sections of this permit including Section B (State Only General Requirements) and/or Section E (Source Group Restrictions).

**SECTION D. Source Level Requirements**

Source ID: 120

Source Name: PARTS WASHERS (2)

Source Capacity/Throughput:

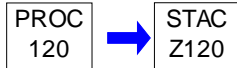
**I. RESTRICTIONS.**

No additional requirements exist except as provided in other sections of this permit including Section B (State Only General Requirements).

**II. TESTING REQUIREMENTS.**

No additional testing requirements exist except as provided in other sections of this permit including Section B (State Only General Requirements).

**III. MONITORING REQUIREMENTS.**

No additional monitoring requirements exist except as provided in other sections of this permit including Section B (State Only General Requirements).

**IV. RECORDKEEPING REQUIREMENTS.**

No additional record keeping requirements exist except as provided in other sections of this permit including Section B (State Only General Requirements).

**V. REPORTING REQUIREMENTS.**

No additional reporting requirements exist except as provided in other sections of this permit including Section B (State Only General Requirements).

**VI. WORK PRACTICE REQUIREMENTS.**

No additional work practice requirements exist except as provided in other sections of this permit including Section B (State Only General Requirements).

**VII. ADDITIONAL REQUIREMENTS.****# 001 [25 Pa. Code §129.63]****Degreasing operations**

(a) Cold cleaning machines. Except for those subject to the Federal National emissions standards for hazardous air pollutants (NESHAP) for halogenated solvent cleaners under 40 CFR Part 63 (relating to National emission standards for hazardous air pollutants for source categories), this subsection applies to cold cleaning machines that use 2 gallons or more of solvents containing greater than 5% VOC content by weight for the cleaning of metal parts.

(1) Immersion cold cleaning machines shall have a freeboard ratio of 0.50 or greater.

(2) Immersion cold cleaning machines and remote reservoir cold cleaning machines shall:

(i) Have a permanent, conspicuous label summarizing the operating requirements in paragraph (3). In addition, the label shall include the following discretionary good operating practices:

(A) Cleaned parts should be drained at least 15 seconds or until dripping ceases, whichever is longer. Parts having cavities or blind holes shall be tipped or rotated while the part is draining. During the draining, tipping or rotating, the parts

**SECTION D. Source Level Requirements**

should be positioned so that solvent drains directly back to the cold cleaning machine.

(B) When a pump-agitated solvent bath is used, the agitator should be operated to produce a rolling motion of the solvent with no observable splashing of the solvent against the tank walls or the parts being cleaned.

(C) Work area fans should be located and positioned so that they do not blow across the opening of the degreaser unit.

(ii) Be equipped with a cover that shall be closed at all times except during cleaning of parts or the addition or removal of solvent. For remote reservoir cold cleaning machines which drain directly into the solvent storage reservoir, a perforated drain with a diameter of not more than 6 inches shall constitute an acceptable cover.

(3) Cold cleaning machines shall be operated in accordance with the following procedures:

(i) Waste solvent shall be collected and stored in closed containers. The closed containers may contain a device that allows pressure relief, but does not allow liquid solvent to drain from the container.

(ii) Flushing of parts using a flexible hose or other flushing device shall be performed only within the cold cleaning machine. The solvent spray shall be a solid fluid stream, not an atomized or shower spray.

(iii) Sponges, fabric, wood, leather, paper products and other absorbent materials may not be cleaned in the cold cleaning machine.

(iv) Air agitated solvent baths may not be used.

(v) Spills during solvent transfer and use of the cold cleaning machine shall be cleaned up immediately.

(4) After December 22, 2002, a person may not use, sell or offer for sale for use in a cold cleaning machine any solvent with a vapor pressure of 1.0 millimeter of mercury (mm Hg) or greater and containing greater than 5% VOC by weight, measured at 20°C (68°F) containing VOCs.

(5) On and after December 22, 2002, a person who sells or offers for sale any solvent containing VOCs for use in a cold cleaning machine shall provide, to the purchaser, the following written information:

(i) The name and address of the solvent supplier.

(ii) The type of solvent including the product or vendor identification number.

(iii) The vapor pressure of the solvent measured in mm hg at 20°C (68°F).

(6) A person who operates a cold cleaning machine shall maintain for at least 2 years and shall provide to the Department, on request, the information specified in paragraph (5). An invoice, bill of sale, certificate that corresponds to a number of sales, Material Safety Data Sheet (MSDS), or other appropriate documentation acceptable to the Department may be used to comply with this section.

(7) Paragraph (4) does not apply:

(i) To cold cleaning machines used in extreme cleaning service.

(ii) If the owner or operator of the cold cleaning machine demonstrates, and the Department approves in writing, that compliance with paragraph (4) will result in unsafe operating conditions.

(iii) To immersion cold cleaning machines with a freeboard ratio equal to or greater than 0.75.

(b) - (e) Not applicable.

**SECTION E. Source Group Restrictions.**

Group Name: G01-LEHRS

Group Description: LEHRS

Sources included in this group

ID	Name
104	QUENCH & SHOCK LEHR
105	ANNEALING LEHRS (7), GLAZERS (1), MISC. HEAT/POL
119	DECORATING LEHR (#1)

**I. RESTRICTIONS.****Emission Restriction(s).****# 001 [25 Pa. Code §123.13]****Processes**

(a)-(b) Not applicable.

(c) For processes not listed in subsection (b)(1), including but not limited to, coke oven battery waste heat stacks and autogeneous zinc coker waste heat stacks, the following shall apply:

(1) Prohibited emissions. No person may permit the emission into the outdoor atmosphere of particulate matter from any process not listed in subsection (b)(1) in a manner that the concentration of particulate matter in the effluent gas exceeds any of the following:

(i) .04 grain per dry standard cubic foot, when the effluent gas volume is less than 150,000 dry standard cubic feet per minute.

(ii)-(iii) Not applicable.

(2) Not applicable.

(d) Not applicable.

**# 002 [25 Pa. Code §123.21]****General**

(a) Not applicable.

(b) No person may permit the emission into the outdoor atmosphere of sulfur oxides from a source in a manner that the concentration of the sulfur oxides, expressed as SO<sub>2</sub>, in the effluent gas exceeds 500 parts per million, by volume, dry basis.**II. TESTING REQUIREMENTS.**

No additional testing requirements exist except as provided in other sections of this permit including Section B (State Only General Requirements).

**III. MONITORING REQUIREMENTS.**

No additional monitoring requirements exist except as provided in other sections of this permit including Section B (State Only General Requirements).

**IV. RECORDKEEPING REQUIREMENTS.****# 003 [25 Pa. Code §127.441]****Operating permit terms and conditions.**

The owner/operator shall maintain a record of all preventative maintenance inspections of the sources. These inspections/maintenance records shall, at a minimum, contain the following:



**SECTION E. Source Group Restrictions.**

- (i) The preventative maintenance schedule;
- (ii) The dates of inspections/maintenance;
- (iii) Description of any problems or defects of the control device;
- (iv) Action taken to correct problems or defects; and
- (v) Any routine maintenance performed.

The owner/operator shall develop and implement a preventative maintenance schedule within 60 days of the issuance date of this operating permit including daily, weekly, monthly, and annual inspections to ensure the source(s)/control device(s) are operating efficiently. These records shall be kept on-site for a minimum period of five years and shall be made available to the Department upon request.

**V. REPORTING REQUIREMENTS.**

No additional reporting requirements exist except as provided in other sections of this permit including Section B (State Only General Requirements).

**VI. WORK PRACTICE REQUIREMENTS.**

**# 004 [25 Pa. Code §127.441]  
Operating permit terms and conditions.**

Compliance with mass emission limits established in this operating permit may be demonstrated using engineering calculations based on fuel and raw material purchase records, manufacturers specifications, AP-42 emission factors (or equivalent), laboratory analyses, source test results, operating records, and material balance methods.

**# 005 [25 Pa. Code §127.441]  
Operating permit terms and conditions.**

The owner/operator shall maintain and operate the sources in accordance with good operating practices.

**VII. ADDITIONAL REQUIREMENTS.**

No additional requirements exist except as provided in other sections of this permit including Section B (State Only General Requirements).



**SECTION E. Source Group Restrictions.**

Group Name: G02-PROCESS

Group Description: Processes controlled by baghouse

Sources included in this group

ID	Name
101	MOLD TRADE SHOP
108	BATCH PLANT

**I. RESTRICTIONS.****Emission Restriction(s).****# 001 [25 Pa. Code §123.13]****Processes**

(a)-(b) Not applicable.

(c) For processes not listed in subsection (b)(1), including but not limited to, coke oven battery waste heat stacks and autogeneous zinc coker waste heat stacks, the following shall apply:

(1) Prohibited emissions. No person may permit the emission into the outdoor atmosphere of particulate matter from any process not listed in subsection (b)(1) in a manner that the concentration of particulate matter in the effluent gas exceeds any of the following:

(i) .04 grain per dry standard cubic foot, when the effluent gas volume is less than 150,000 dry standard cubic feet per minute.

(ii)-(iii) Not applicable.

(2) Not applicable.

(d) Not applicable.

**# 002 [25 Pa. Code §123.21]****General**

(a) Not applicable.

(b) No person may permit the emission into the outdoor atmosphere of sulfur oxides from a source in a manner that the concentration of the sulfur oxides, expressed as SO<sub>2</sub>, in the effluent gas exceeds 500 parts per million, by volume, dry basis.**II. TESTING REQUIREMENTS.**

No additional testing requirements exist except as provided in other sections of this permit including Section B (State Only General Requirements).

**III. MONITORING REQUIREMENTS.**

No additional monitoring requirements exist except as provided in other sections of this permit including Section B (State Only General Requirements).

**IV. RECORDKEEPING REQUIREMENTS.****# 003 [25 Pa. Code §127.441]****Operating permit terms and conditions.**

The owner shall record the monthly magnehelic readings of the baghouse when the source and control devices are in operation. The log shall be kept on-site for a minimum period of five years and made available to the Department upon request.

**SECTION E. Source Group Restrictions.****# 004 [25 Pa. Code §127.441]****Operating permit terms and conditions.**

The owner/operator shall maintain a record of all preventative maintenance inspections of the sources. These inspections/maintenance records shall, at a minimum, contain the following:

- (i) The preventative maintenance schedule;
- (ii) The dates of inspections/maintenance;
- (iii) Description of any problems or defects of the control device;
- (iv) Action taken to correct problems or defects; and
- (v) Any routine maintenance performed.

The owner/operator shall develop and implement a preventative maintenance schedule within 60 days of the issuance date of this operating permit including daily, weekly, monthly, and annual inspections to ensure the source(s)/control device(s) are operating efficiently. These records shall be kept on-site for a minimum period of five years and shall be made available to the Department upon request.

**V. REPORTING REQUIREMENTS.**

No additional reporting requirements exist except as provided in other sections of this permit including Section B (State Only General Requirements).

**VI. WORK PRACTICE REQUIREMENTS.****# 005 [25 Pa. Code §127.441]****Operating permit terms and conditions.**

The owner/operator shall operate the control devices at all times the source is in operation.

**# 006 [25 Pa. Code §127.441]****Operating permit terms and conditions.**

A magnehelic gauge or equivalent shall be permanently installed and maintained at a convenient location to indicate the pressure drop across the baghouse. The gauge shall have a scale such that the expected normal reading shall be no less than twenty percent (20%) of full scale and be accurate within plus or minus two percent (+/- 2%) of full scale reading.

**# 007 [25 Pa. Code §127.441]****Operating permit terms and conditions.**

The control devices shall be operated and maintained in accordance with good operating practices.

**# 008 [25 Pa. Code §127.441]****Operating permit terms and conditions.**

Compliance with mass emission limits established in this operating permit may be demonstrated using engineering calculations based on fuel and raw material purchase records, manufacturers specifications, AP-42 emission factors (or equivalent), laboratory analyses, source test results, operating records, and material balance methods.

**VII. ADDITIONAL REQUIREMENTS.**

No additional requirements exist except as provided in other sections of this permit including Section B (State Only General Requirements).



**SECTION F. Alternative Operation Requirements.**

No Alternative Operations exist for this State Only facility.



**SECTION G. Emission Restriction Summary.**

No emission restrictions listed in this section of the permit.

## SECTION H. Miscellaneous.

The following sources have been determined to be insignificant sources with respect to emissions and exempt from Plan Approval/Operating Permit requirements in accordance with 25 Pa. Code §127.14(8):

Paved and Unpaved Roads  
Sandblasting Operation  
Acetylene Tanks  
Cullet Crusher  
Glass forming

For the purpose of this operating permit, compliance with the NO<sub>x</sub> emission rate of 1.36 lb/ton of glass pulled on a rolling 30-day average for Source 103 ensures compliance with the following applicable limitations:

1. The facility's NO<sub>x</sub> emissions shall not exceed 5 lbs per ton of glass produced and 279 tons per consecutive 12 month period. [Pursuant to RACT Operating Permit # 04-000-084 (issued on 10/13/1995) and Title V Operating Permit # 04-00084 (issued on 12/11/2000)]

2. Per 25 Pa. Code §129.304:

(a) Except as specified in §§ 129.303, 129.304(c), 129.305, 129.306 and 129.307, the owner or operator of a glass melting furnace may not operate the glass melting furnace in a manner that results in NO<sub>x</sub> emissions in excess of the following allowable limits or NO<sub>x</sub> emission limits contained in the plan approval or operating permit, whichever are lower:

- (1) Not applicable.
- (2) 7.0 pounds of NO<sub>x</sub> per ton of glass pulled for pressed or blown glass furnaces.
- (3)-(5) Not applicable.

For the purposes of complying with the malfunction reporting requirements of Section C, Condition #019, it is the Department's understanding that the facility's use of the melt tank bypass stack when operated in accordance with the applicable conditions of this operating permit, is not considered a reportable malfunction or emergency.



\*\*\*\*\* End of Report \*\*\*\*\*

---